

TUK-5080VM

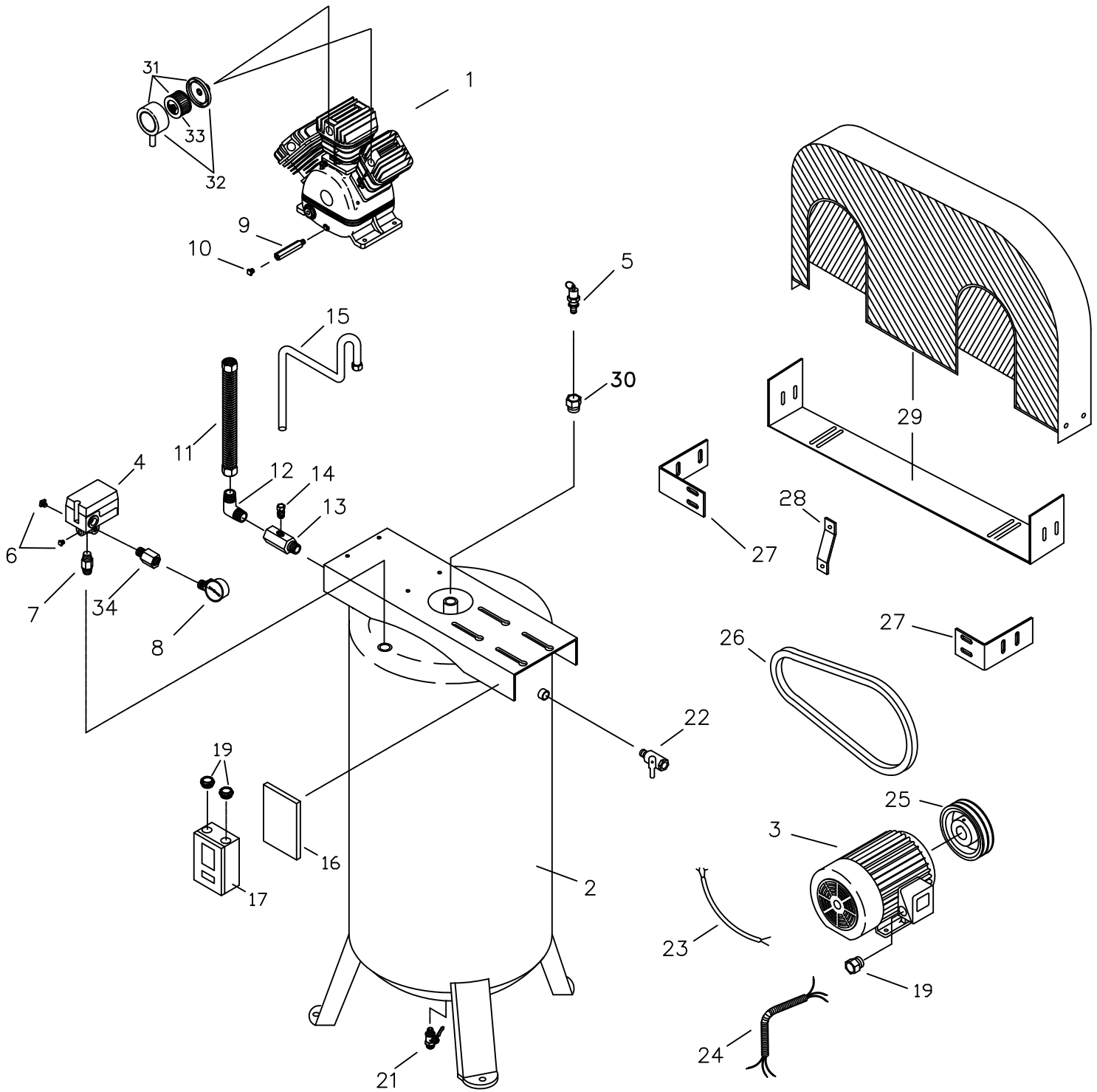

PUMA INDUSTRIES, INC.
MEMPHIS, TN.
U.S.A.

VER.: VE-001

PARTS LIST

Model: TUK-5080VM

VERSION: VE-001

REF. NO.	PARTS ID	DESCRIPTION	QUANTITY
1	TK50	PUMP	1.00
2	4001-80V	TANK	1.00
3	4027-50-41	MOTOR	1.00
4	2E21-AF357DM	PRESSURE SWITCH	1.00
5	84006010	PRESSURE RELIEF VALVE	1.00
6	2B14-ST02E	PLUG	2.00
7	2N01-001	NIPPLE	1.00
8	2D12-20V20K	PRESSURE GAUGE	1.00
9	2305008	OIL DRAIN TUBE	1.00
10	2N33-002	OIL PLUG	1.00
11	3B2-06*570	DISCHARGE TUBE	1.00
12	2N06-06T06H	ELBOW	1.00
13	CV3434M	CHECK VALVE	1.00
14	035-02RN01MN-00	TUBE FITTING	1.00
15	063-CU01X750	TUBE (CHECK VALVE - PRESSURE SWITCH)	1.00
16	3417010	BRACKET (for STARTER)	1.00
17	MS-50-1S	MAGNETIC STARTER	1.00
19	025A-06N-000	WIRE CLAMP (on Starter & Motor)	3.00
21	2413020	DRAIN VALVE	1.00
22	2413007	SERVICE VALVE	1.00
23	2E02-3530702Y2F	ELECTRIC CABLE (STARTER - P.S.)	1.00
24	025K-7580VM-R	ELECTRIC CABLE (STARTER - MOTOR)	1.00
25	2AH83	PULLEY	1.00
25	048A-H11SS-000	PULLEY HUB	1.00
26	2N31-A66	BELT (A66)	2.00
27	3427028	BRACKET - RIGHT & LEFT	2.00
28	3427015	BRACKET - CENTER	1.00
29	3427202	BRACKET - BOTTOM	1.00
29	3426024	BELT GUARD	1.00
30	050-06MN02FN	REDUCE BUSHING	1.00
31	2140009A	AIR FILTER ASSEMBLY	2.00
32	2140009	AIR FILTER HOUSING	2.00
33	1801 (2142002)	FILTER ELEMENT	2.00
34	2N02-02T02NC	ADAPTOR	1.00

MODEL : TK-50

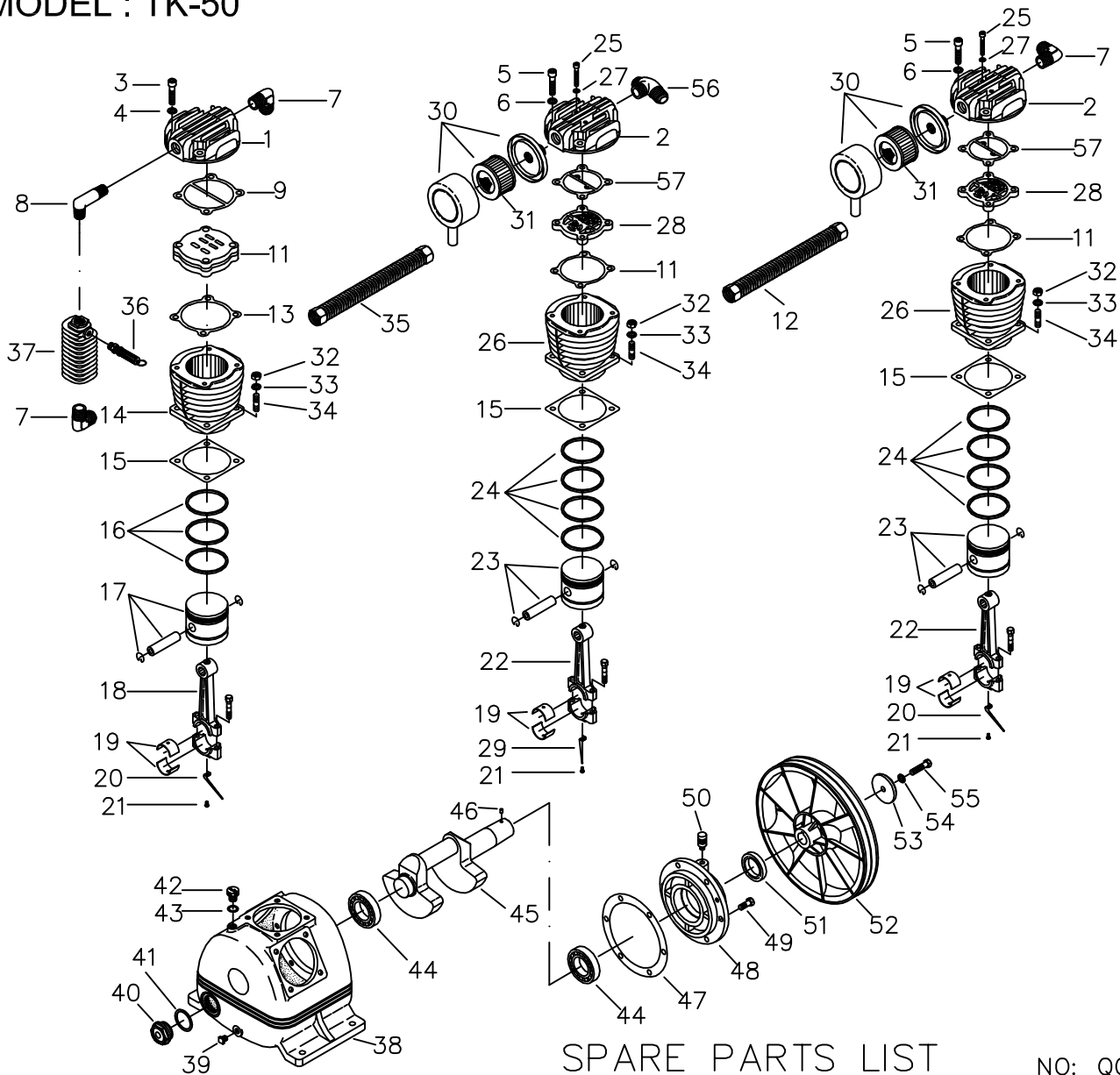

SPARE PARTS LIST

NO: QC-0203

REF. NO.	DESCRIPTION	PART NO.	QTY	REF. NO.	DESCRIPTION	PART NO.	QTY
1	Cylinder head	3101043	1	30	Air filter	2140009	2
2	Cylinder head	3101018	2	31	Filter element	2142002	2
3	Hex socket bolt	2B01-M06*040	4	32	Hex nut	2B20-FM10	12
4	Lock washer	2B33-M06	4	33	Lock washer	2B33-M10	12
5	Hex socket bolt	2B01-M10*050	8	34	Stud screw	2B11-003	12
6	Flat washer	2B33-M10	8	35	Discharge tube set	3B2-06*490	1
7	Discharge elbow	2N06-06T06H	3	36	Pressure relief valve	2406007	1
8	Discharge elbow	2N06-06T06T85	1	37	Intercooler	3125001	1
9	Cylinder head gasket	2G01-015	1	38	Crankcase	3301017	1
10	In. & Ex. valve assembly	3B13-K51	1	39	Oil draining plug	2N33-002	1
11	Valve plate gasket	2G03-005	2	40	Oil sight gauge	2303004	1
12	Discharge tube set	3B2-06*235	1	41	Oil sight gauge gasket	2G11-003	1
13	Valve plate gasket	2G03-010	1	42	Oil cap	2319004	1
14	Cylinder	3201029	1	43	O-ring	2N52-30*15	1
15	Cylinder gasket	2G04-009	3	44	Bearing	2N35-6306	2
16	Piston ring set (HP)	3B32-65	1	45	Crankshaft & counterweight	3304025	1
17	Piston set (HP)	3B31-T65	1	46	Pulley key	2N47-63*09	1
18	Rod	2315022A	1	47	Rear bearing end gasket	2G06-002	1
19	Bearing (rod bushing)	2316001	6	48	Rear bearing end	3311003	1
20	Oil splasher	2317019	2	49	Hex socket bolt	2B00-SM10*025	6
21	Bolt (+)	2B02-FM5*010	3	50	Breather	2321008	1
22	Rod	2315018	2	51	Oil seal	2N50-TC30*50*11	1
23	Piston set (LP)	3B31-80L	2	52	Pulley	3PBF-145A230	1
24	Piston ring set (LP)	3B32-80	2	53	Washer	2B34-13*52*14	1
25	Hex socket bolt	2B01-M06*055	4	54	Lock washer	2B33-M12	1
26	Cylinder	3201015	4	55	Hex socket bolt	2B00-SM12*050	1
27	Lock washer	2B31-005	4	56	Tee	2N09-06H06T06H2	1
28	In. & Ex. valve assembly	3B13-AP80	2	57	Cylinder head gasket	2G01-011	2
29	Oil splasher	2317018	1	58			

Warning: This diagram is for your reference only. Please check with a qualified electrician for wiring to meet your local electrical wiring code.

Manufacturer assumes no responsibility for changes to factory wiring.

Electrical Circuit Diagram: (For Shihlin model : S-P30T starter)

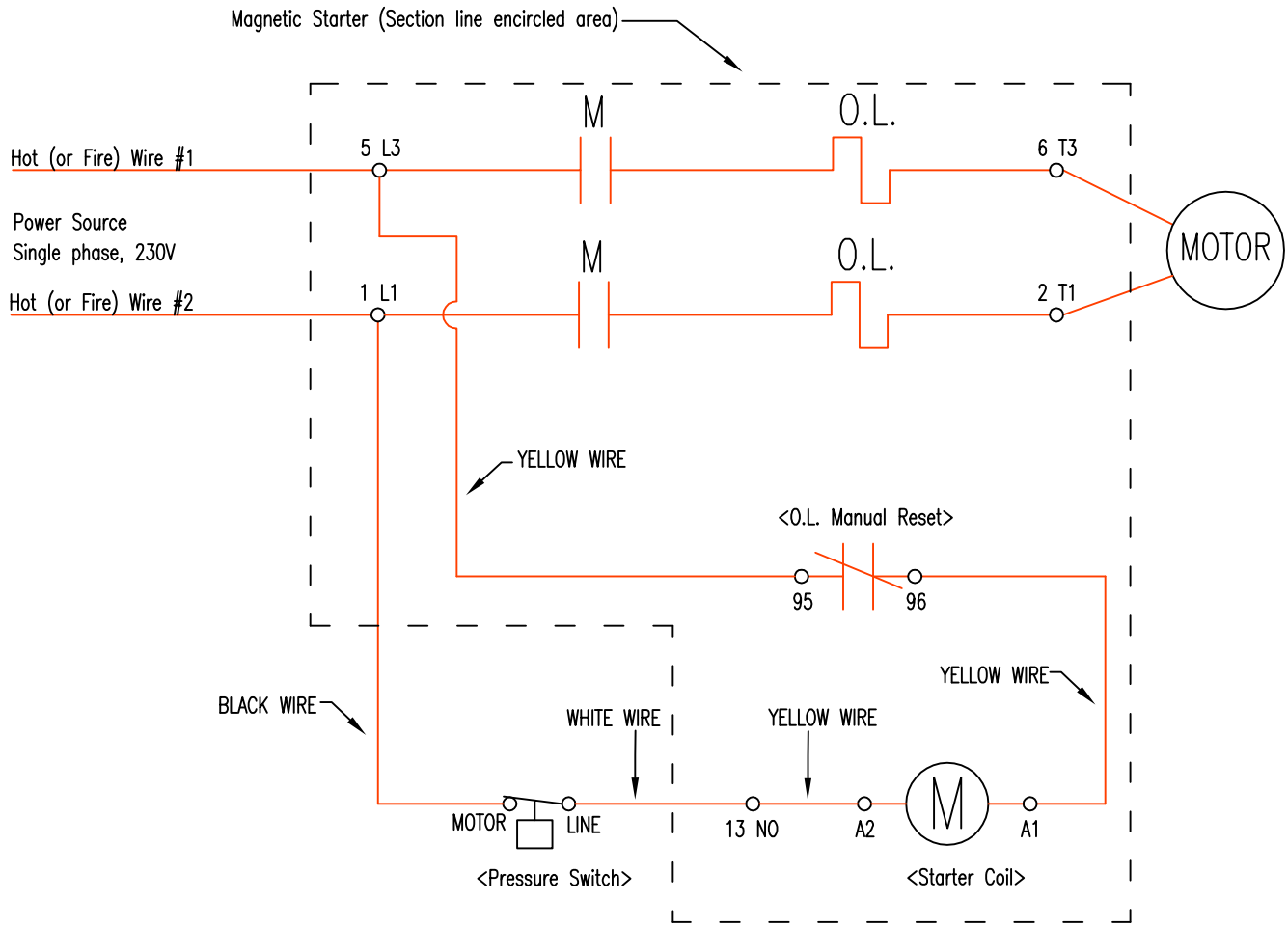

P.S. Ground (Green) wires are not shown in this drawing.

Additional instructions and warning:

* The breaker size (trip rating) for Circuit Breaker (trip style) is suggested at 60A. For Fusible Switch (Melting Style), the 40A dual element time delay fuses are suggested. For correct rating of Breaker and Switch, please consult with a qualified electrician.

** Minimum COPPER wire size : AWG10 The maximum wire length allowed: 10ft. when measured from breaker/switch (power source) to magnetic starter (on unit).

*** Voltage: Single Phase 208~230V only. The voltage must be maintained at this range (208V~230V) through out entire compressor operation (from start to stop). Voltage drops below 208V or rises beyond 230V will result in motor and starter failures.

WARNING: ONLY wire power lines to magnetic starter (5L3 & 1L1). NEVER wire them to pressure switch.